

# *Measurement of stau-neutralino mass differences*

*Olga Stempel  
DESY*

*Hamburg, 24 Jan.2008*

# Goal of my analysis

- Optimisation of  $e^+e^-$ -Detector

- Analysis exists in fast simulation (SIMDET)  
(Based on the TESLA detector)

TASK: the analysis in full simulation  $\leftrightarrow$  more detector details  
In view of: detector optimisation

- Dark Matter candidate:  $\chi^0_1$

From astrophysics: Dark Matter relic density is  $\approx 20\text{-}30\%$

Can be determined by  $\tilde{\tau}_1$  co-annihilation in SUSY scenarios with  
a neutralino-LSP

# SUSY-Scenario SPS 1a'

## Dark Matter

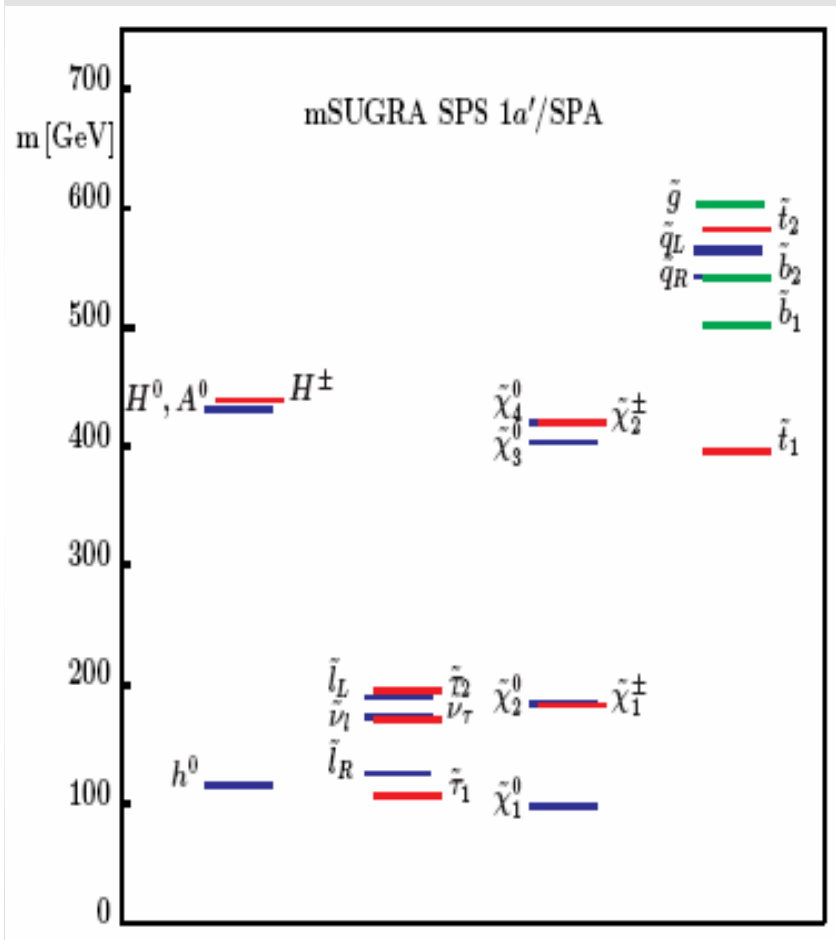

- lightest superparticle (LSP)  
 $m_{\text{neutralino}} = 125.2 \text{ GeV}$
- next-to-lightest superparticle (NLSP)  
 $m_{\text{stau}} = 133.2 \text{ GeV}$
- $\Delta m \approx 8 \text{ GeV}$

LSP  $\rightarrow$  natural candidate for cold dark matter

$\tilde{\tau}_1$  Co-Annihilation depends on  $\Delta m_{(\text{stau-neutralino})}$

$\Rightarrow$  DM relic density can be determined

# Stau-Stau-Production

$$e^+_L e^-_R \rightarrow \tilde{\tau}_1 \tilde{\tau}_1 \rightarrow \tau^+ \chi^0_1 \tau^- \chi^0_1$$

For the identification and reconstruction of  $\tau$  pairs:

The measurement of energy spectra:

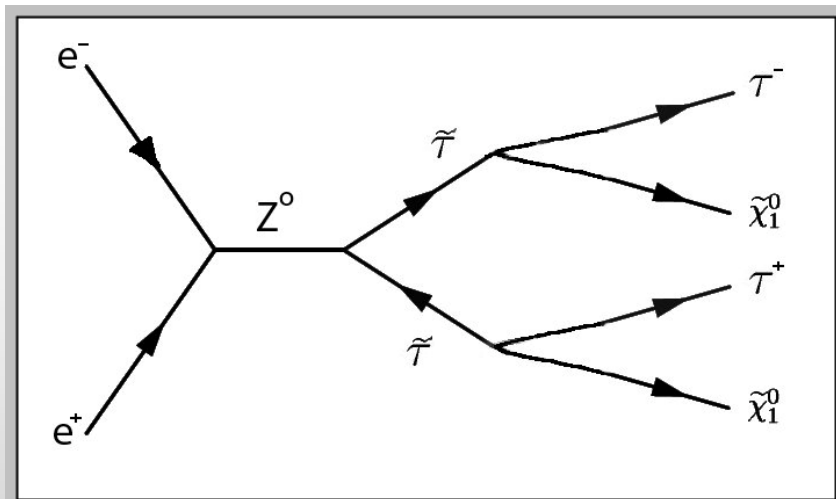

hadronic decay modes:

$$\tau \rightarrow \pi \nu_\tau \quad (11.1\%)$$

$$\tau \rightarrow \rho \nu_\tau \rightarrow \pi^\pm \pi^0 \nu_\tau \quad (25.4\%)$$

$$\tau \rightarrow 3\pi \nu_\tau \rightarrow \pi^\pm \pi^+ \pi^- \nu_\tau + \pi^\pm \pi^0 \pi^0 \nu_\tau \quad (19.4\%).$$

The leptonic 3-body decays:

$$\tau \rightarrow e \nu_e \nu_\tau$$

$$\tau \rightarrow \mu \nu_\mu \nu_\tau$$

- Small percentage ( compared to hadronic decay)
- The decay cannot be reconstructed due two neutrinos per tau-decay.

# Background: $WW$ -Production

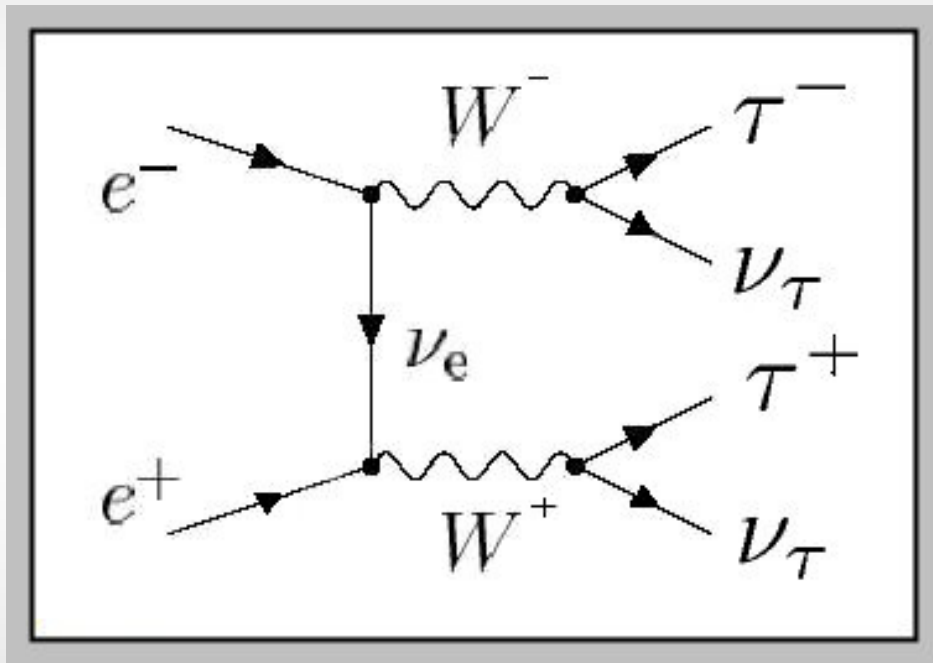

The SM contribution from  $WW$  production is nonsignificant due to the beam polarisation.

Beam polarisations:

- $P_{e^-} = +0.8$  for right-handed electrons
- $P_{e^+} = -0.6$  for left-handed positrons

# Background: $\gamma\gamma$ -Process (1)

## An effective reduction of $\gamma\gamma$ :

An efficient veto of the spectator electrons/positrons down to very small scattering angles is important.

→ optimisation of the forward detector instrumentation is required

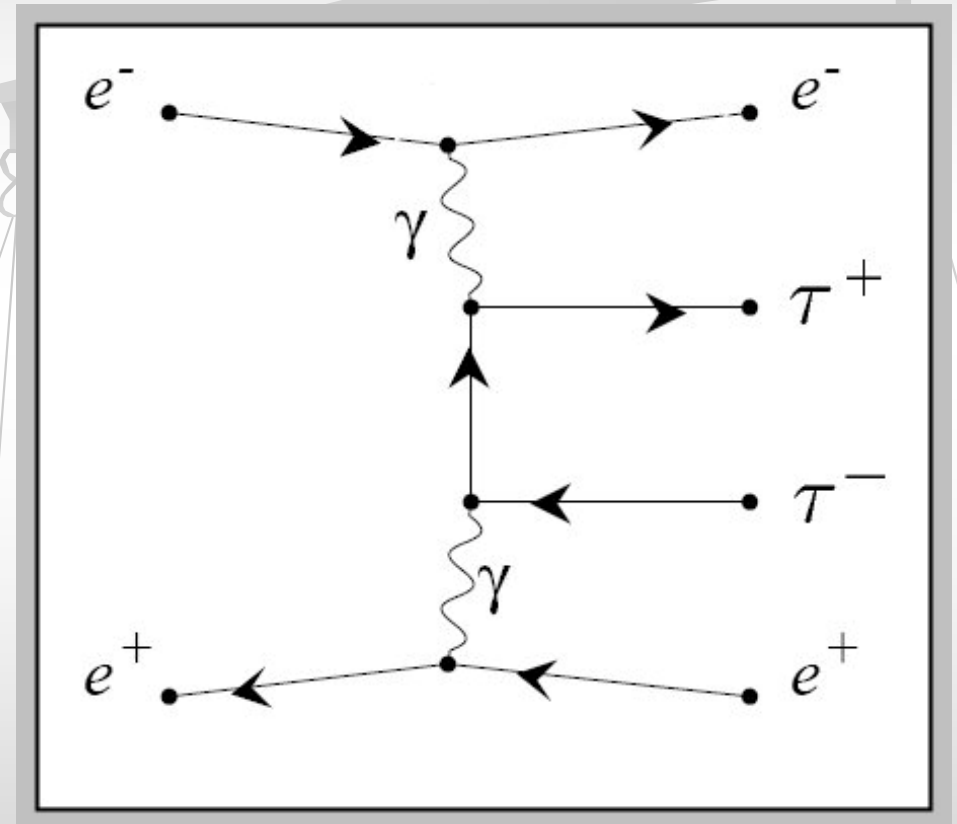

# $\tilde{\tau}_1 \tilde{\tau}_1$ events selection (1)

- ❖ veto of any electromagnetic energy (e or  $\gamma$ ) above 5 GeV in the forward region  $\theta < 125$  mrad
  - suppression of four fermion production via two-photon ( $\gamma\gamma$ ) processes
- ❖ two  $\tau$  candidates within the polar angle  $-0.75 < \cos \theta_\tau < 0.75$ 
  - suppression of WW- production
- ❖ invariant mass of  $\tau$  jet  $m_\tau < 2$  GeV
- ❖ Tau energy  $2 < E_\tau < 25$  GeV
  - to distinguish "hadronic" tau-jets from normal hadronic jets (originating from quarks/gluons)

# $\tilde{\tau}_1 \tilde{\tau}_1$ events selection (2)

- ❖ acoplanarity angle  $\Delta \varphi_{\tau\tau} < 160^\circ$ 
  - suppression of  $e^+e^- \rightarrow \tau^+\tau^-$  processes
  - suppression of WW-production
- ❖ missing momentum vector  $\cos \theta_{\text{pmiss}} < 0.8$
- ❖ transverse momentum of di-tau system  $3 < p_{\tau\tau} < 25 \text{ GeV}$ 
  - suppression of  $\gamma\gamma$ -Background
- ❖ combined cut on  $\Sigma p_{p_{\tau, T}}$  and  $\Delta\varphi^{\tau\tau}$ 
  - most effective way to suppress the  $\gamma\gamma$ -Background (!)

# Background: $\gamma\gamma$ -Process (2)

combined cut on  $\Sigma p_{\perp, T}^{\tau}$  and  $\Delta\phi^{\tau\tau}$

$\Sigma p_{\perp, T}^{\tau} \Rightarrow$  sum of the momentum projections onto the thrust axis

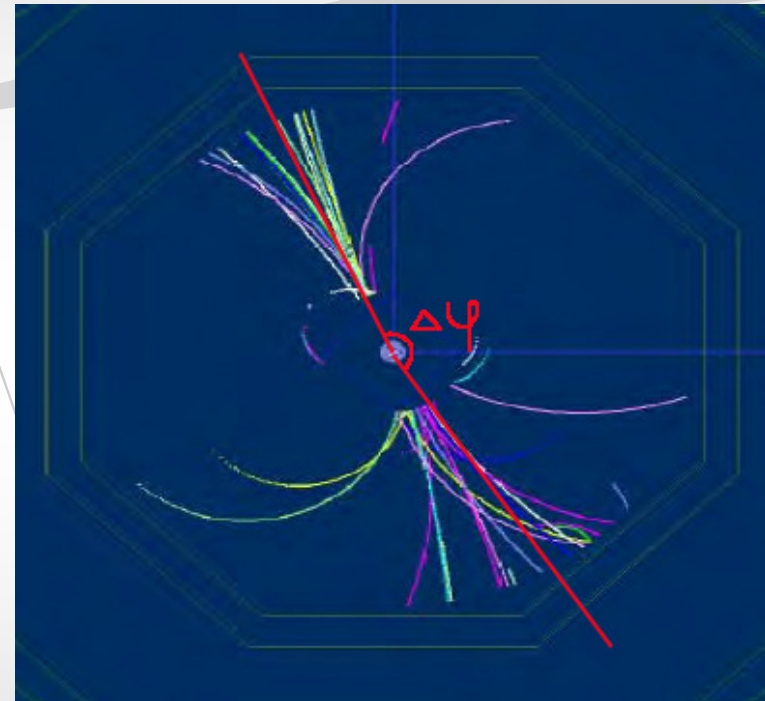
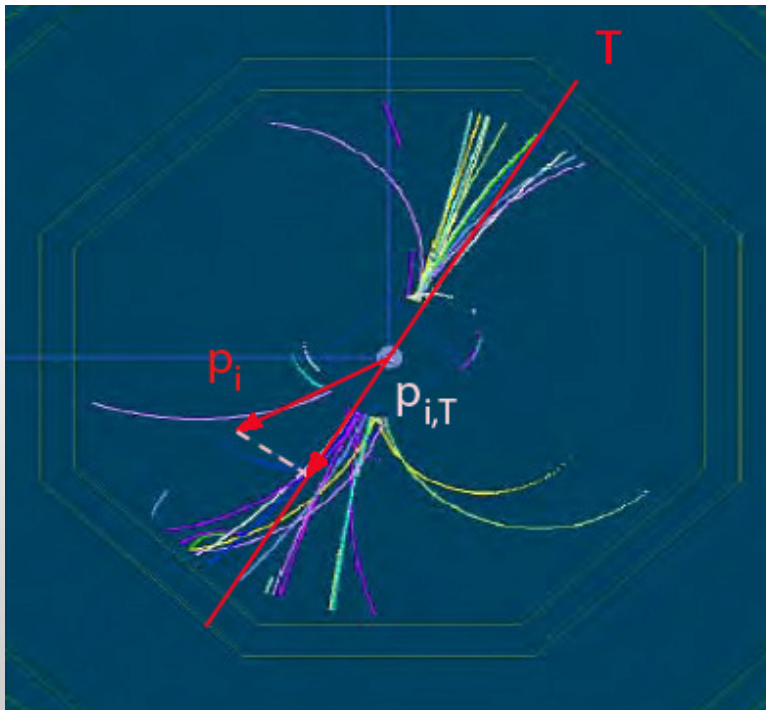

$\Delta\phi^{\tau\tau} \Rightarrow$  angle between two taus in a plane perpendicular to the beam

# $\gamma\gamma$ background (3)

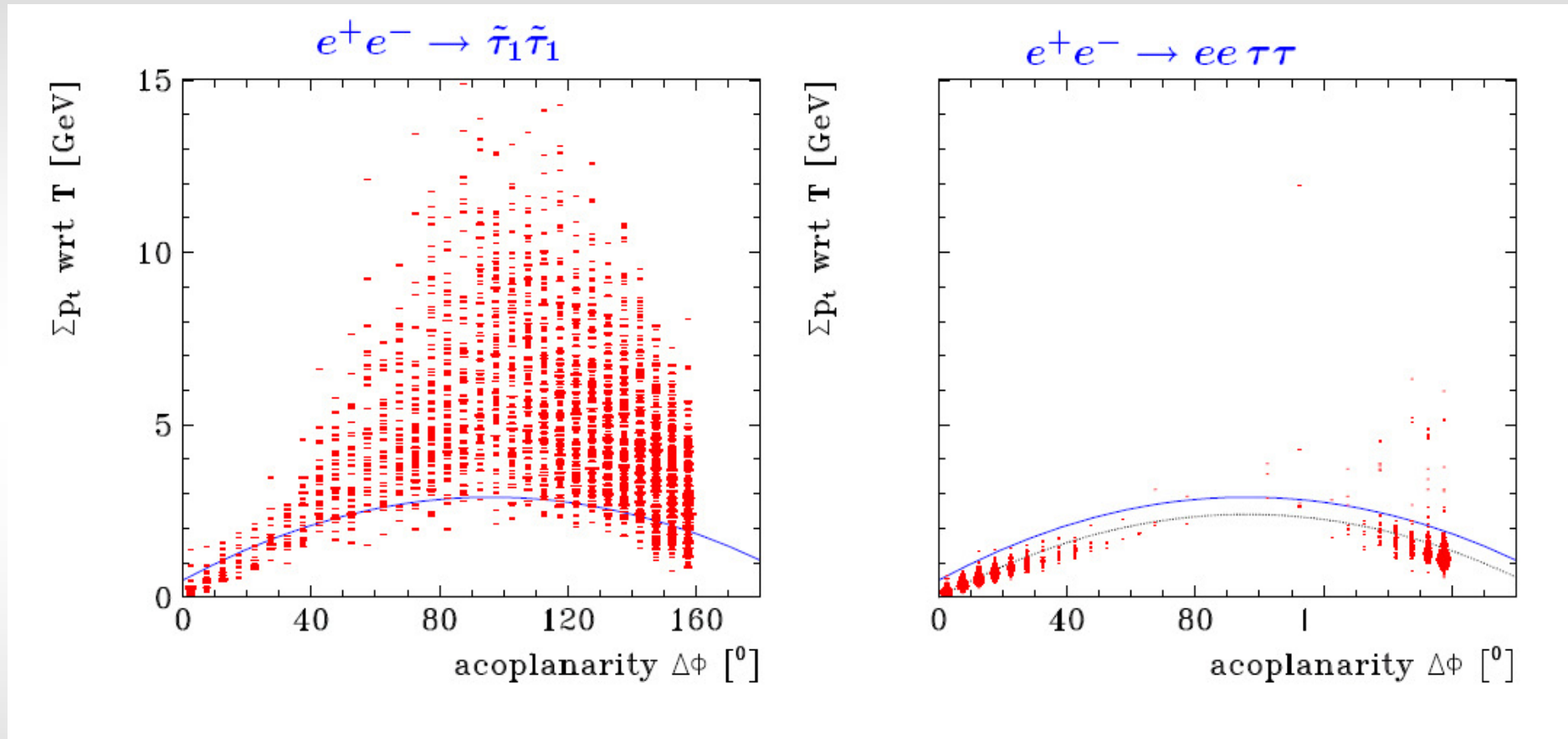

Correlations of  $\Sigma p_{t,T}$  wrt thrust axis  $T$  versus acoplanarity angle  $\phi^{\tau\tau}$  in a plane perpendicular to the beams for  $e^+e^- \rightarrow \tilde{\tau}_1\tilde{\tau}_1 \rightarrow \tau^+ \chi^0_1 \tau^- \chi^0_1$  (left) and  $e^+_L e^-_R \rightarrow e^+ e^- \tau^+ \tau^-$  (right). The curves indicate the separation between SUSY and  $\gamma\gamma$  processes.

# Work schedule

- Analysis in MarlinReco:
  1. Tau identification and reconstruction:
    - 1 or 3 tracks
    - Narrow collimated jets
  2. Analysis of simulated MC-data:
    - $E_\tau$ , PFA,  $2 \text{ GeV} < E_\tau < 25 \text{ GeV}$
    - acoplanarity angle  $\Delta \varphi_{\tau\tau} < 160^\circ$
    - Background reduction
- Replacement: SIMDET  $\rightarrow$  Mokka