Understanding LDC Tracking and New SIT Driver

Hengne Li @ LAL

Thanks to: F. Richard, R. Poeschl @ LAL

A. Raspereza, X. Chen @ MPI

M. Ohlerich @ DESY

OUTLINE

- Introductory Remarks of Track Reconstruction
- What we want to do
- Problems we meet
- Techniques of LDC Track Reconstruction
- Some studies after understanding
- New SIT Driver
- Next Steps..

Introductory Remarks of Track Reconstruction

- A Track of a Charged particle can be described by a Helix:
- A Helix can be defined by a suit of parameters: $(\Omega, D_0, Z_0, \Phi_0, \tan(\lambda))$
- Track Reconstruction is to Fit the helix from hits in the tracking system.
- Usage of a track: momentum, identify particles, etc.

$$P_T = cQB / \Omega$$

$$P_Z = cQB \tan(\lambda) / \Omega$$

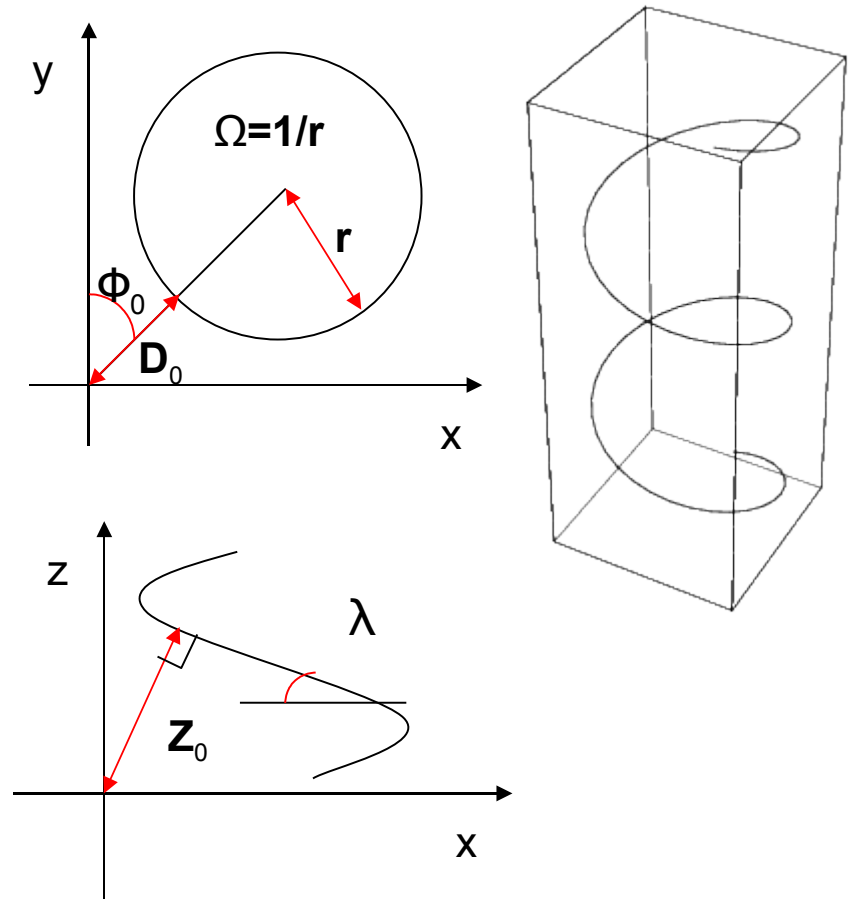

Introductory Remarks of Track Reconstruction

- A Track of a Charged particle can be described by a Helix:
- A Helix can be defined by a suit of parameters: $(\Omega, D_0, Z_0, \Phi_0, \tan(\lambda))$
- Track Reconstruction is to Fit the helix from hits in the tracking system.
- Usage of a track: momentum, identify particles, etc.

$$P_T = cQB / \Omega$$

$$P_Z = cQB \tan(\lambda) / \Omega$$

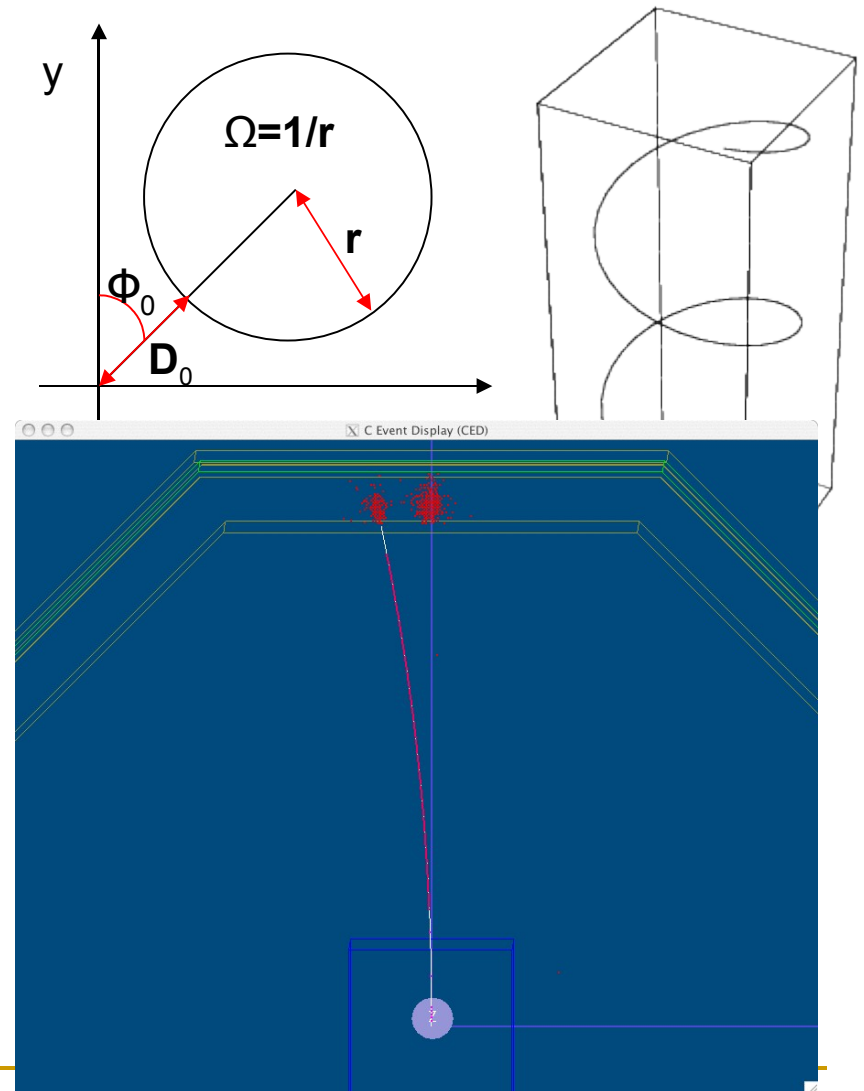

What we want to do?

- Higgs Recoil Mass reconstruction

$$e^+ e^- \rightarrow H Z_0 \rightarrow X e^+ e^-$$

$$m_h^2 = s + m_Z^2 - 2 E_Z \sqrt{s}$$

- $E_z \sim P_z$, and P_z can be calculated from the momentum of the electron/positron pair

- First attempts I did are:

- Mokka (GEANT4) simulation:

- LDC01Sc model
- Particle Gun, shoot electrons

- Marlin Reconstruction:

- FullLDCTracking: **C++ Wrapper of DELPHI Fortran Fitting Codes**
 - DELPHI Codes: DELPHI Collaboration
 - FullLDCTracking: A. Raspereza
- DELPHI Fit:
 - Method: **Kalman Filter**

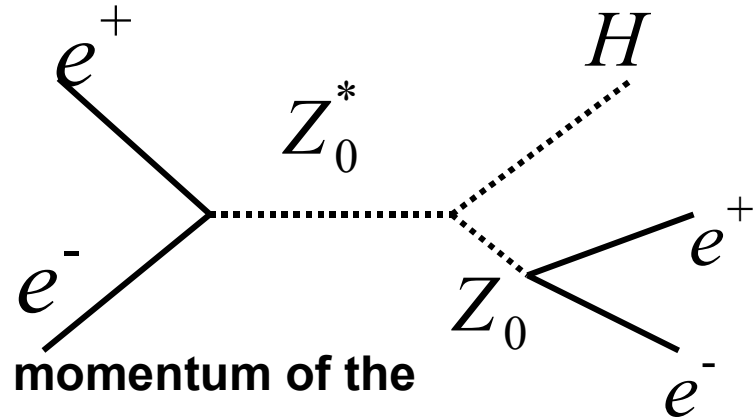

Problems we meet

- **Electron Momentum:**
 - A significant tail in the electron momentum distribution
- **Reason:**
 - Multiple scattering and Radiation of photons are evident for electrons
- **Correction Procedure?**
 - Tried to correlate radiation events with Chi2 of track fit: **FAILED! Why?**
- **Understand the Current LDC Track Reco Methods AT FIRST!**

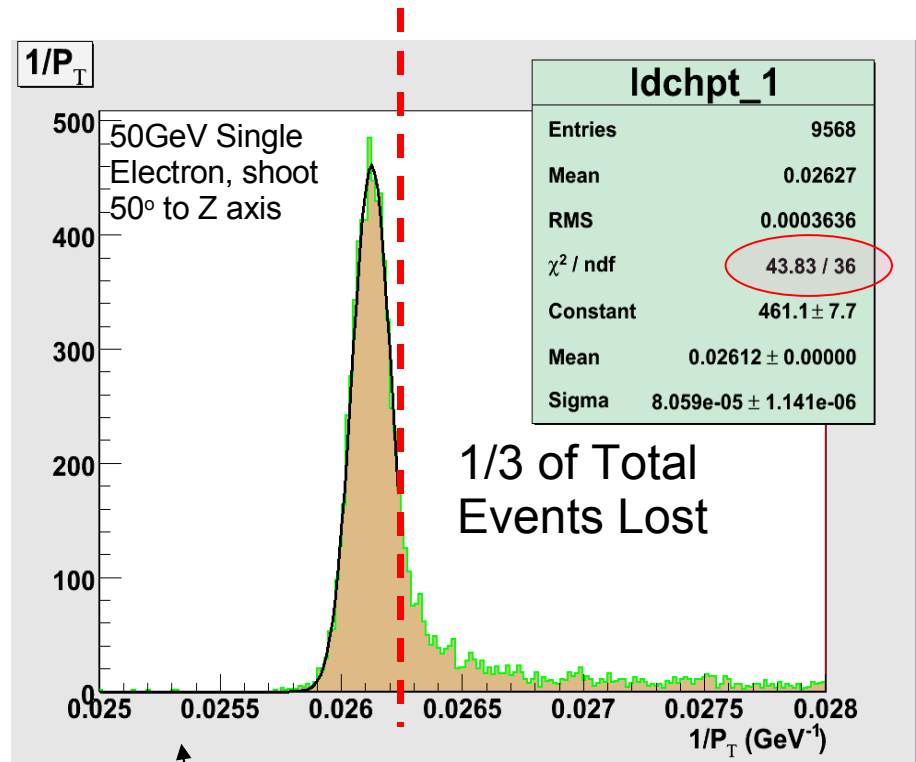

Photon

Electron

$$P_T = cQB / \Omega$$

$$1 / P_T = \Omega / (cQB)$$

$$\Omega \uparrow \Rightarrow 1 / P_T \uparrow$$

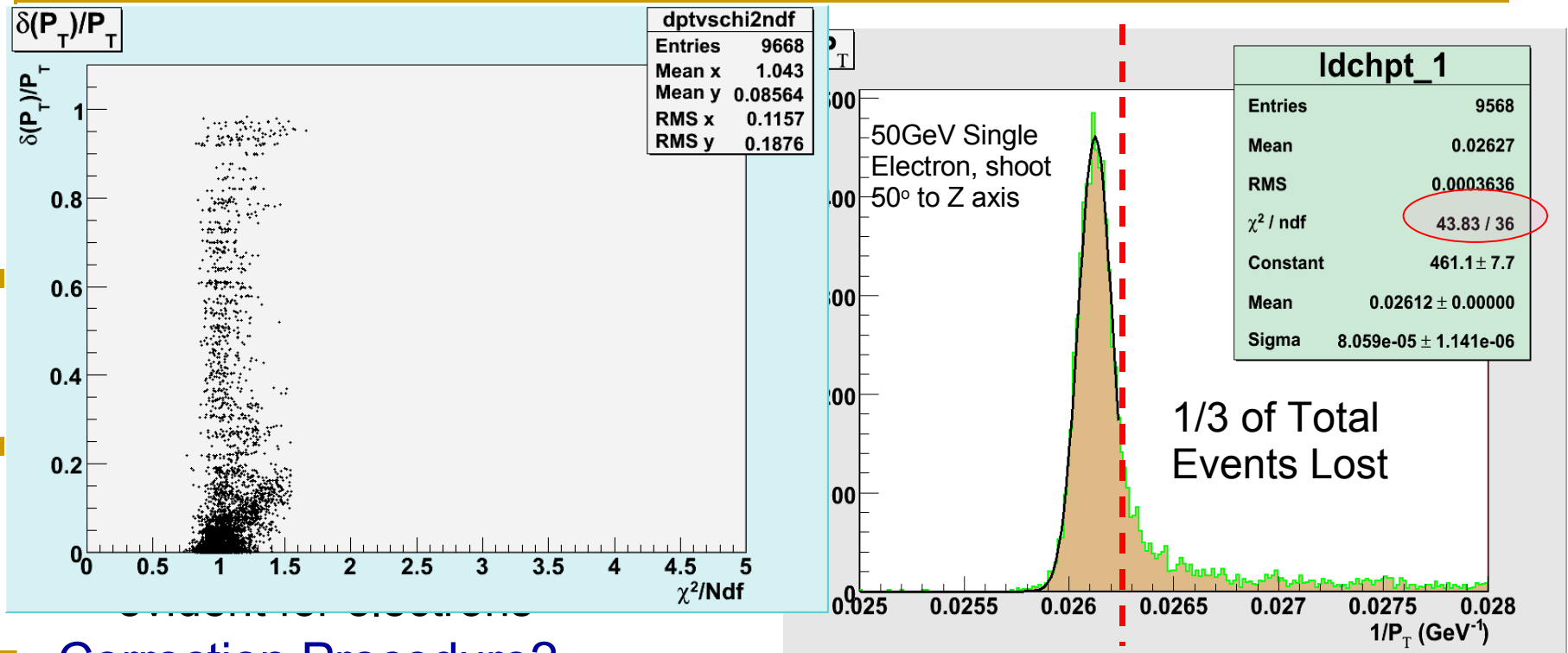

Correction Procedure?

- Tried to correlate radiation events with Chi2 of track fit: **FAILED! Why?**

Understand the Current LDC Track Reco Methods AT FIRST!

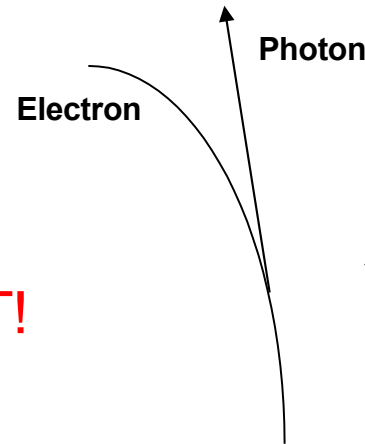

$$P_T = cQB / \Omega$$

$$1/P_T = \Omega / (cQB)$$

$$\Omega \uparrow \Rightarrow 1/P_T \uparrow$$

Techniques of LDC Track Reconstruction

SiliconTracking
(VXD+SIT+FTD)

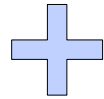

LEPTrackingProcessor
(TPC)

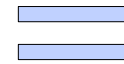

FullLDCTracking
(VXD+SIT+FTD+TPC)

Linking & Refitting

SiTracks



TPCTracks



LDCTracks

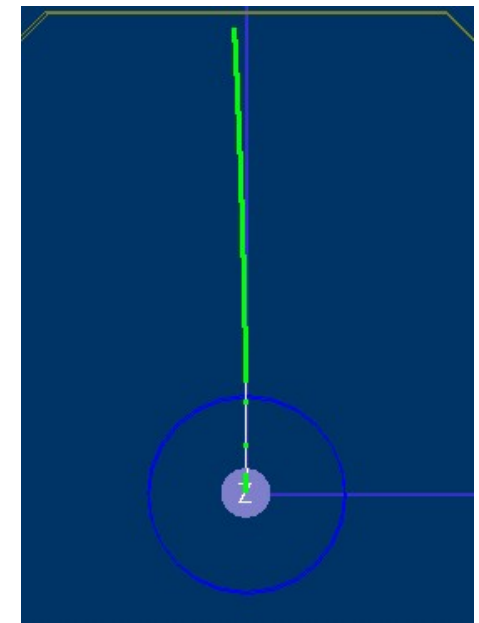
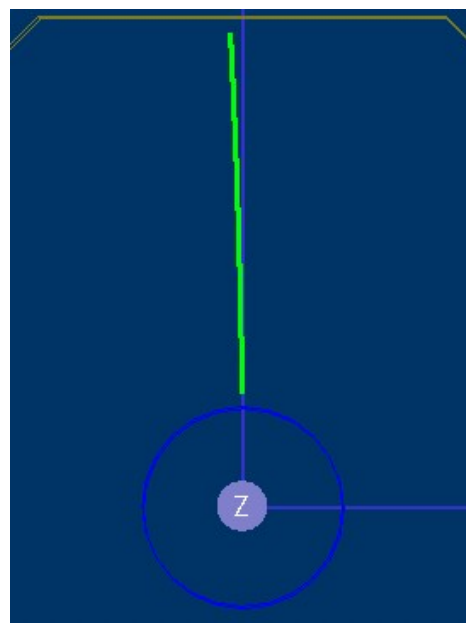
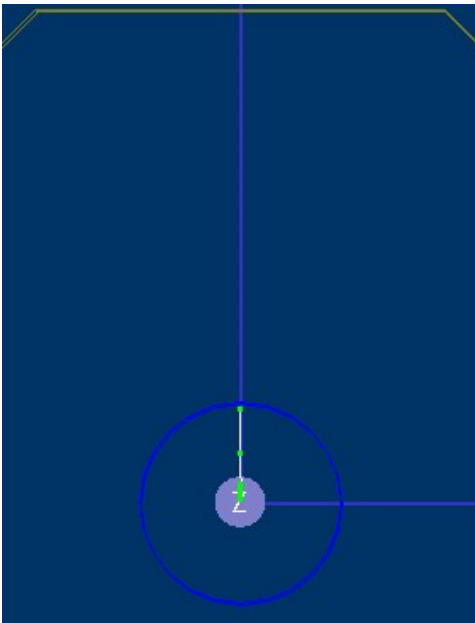

Techniques of LDC Track Reconstruction

A) Kalman Fit

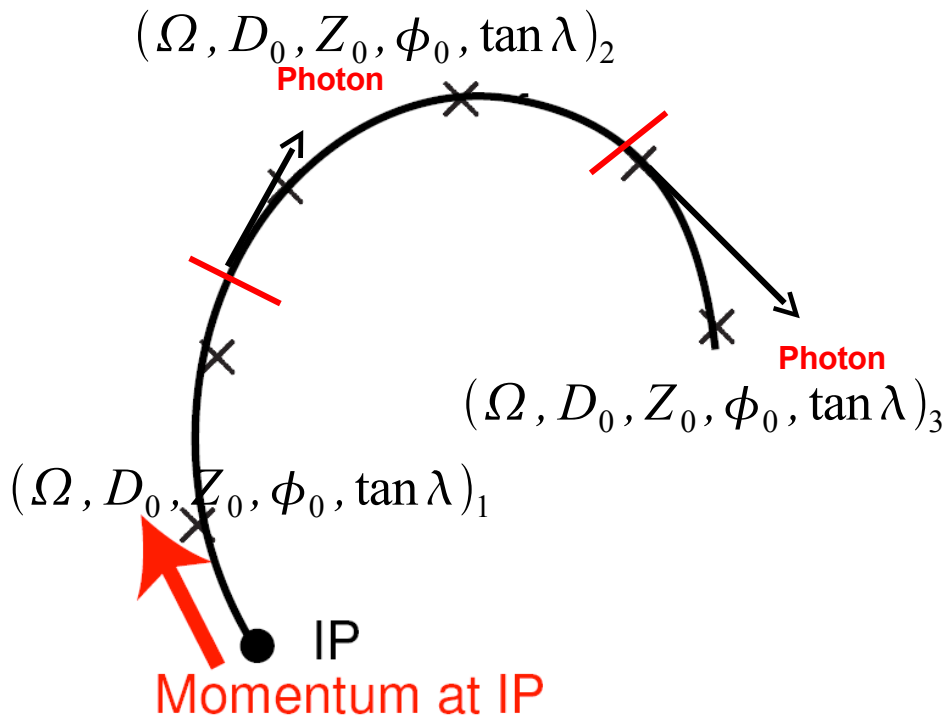

- Several Helix Segments
- Each segment has its own parameters

B) Helix Fit

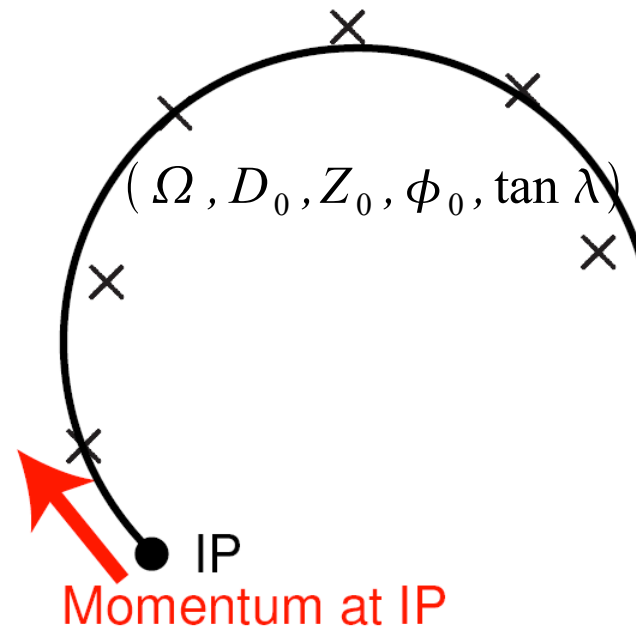

- One Helix
- One suit of Parameters

Techniques of LDC Track Reconstruction

- Currently, The C++ wrapper output only the Helix parameters of the First Segment
 - **Well suited** for momentum reconstruction
 - Discard the info of latter on segments
 - Not enough for Particle Identification
 - Technical Remark: Seems LCIO is NOT ready to store these multi-segment tracks

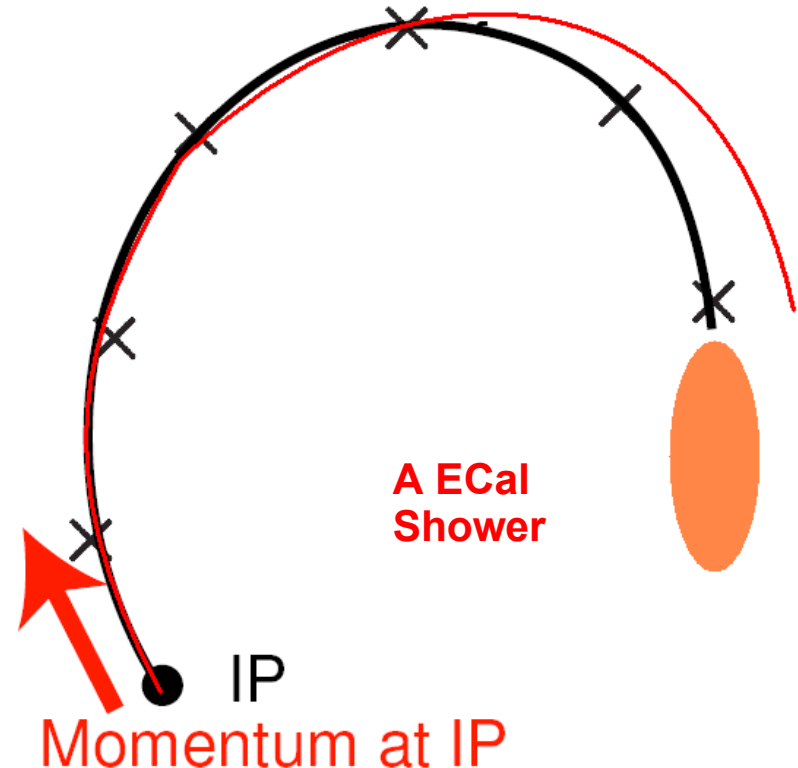

Techniques of LDC Track Reconstruction

■ Reconstruction scenarios:

Radiate BEFORE
TPC

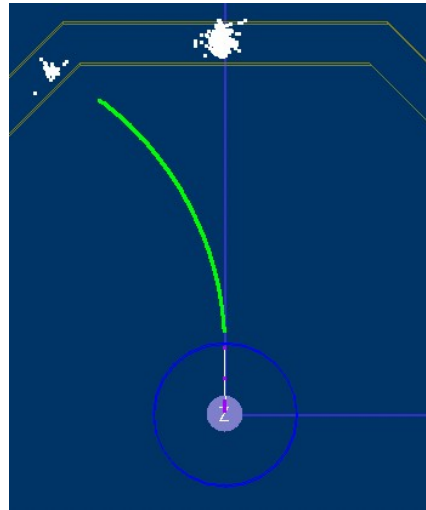

Radiate WITHIN
TPC

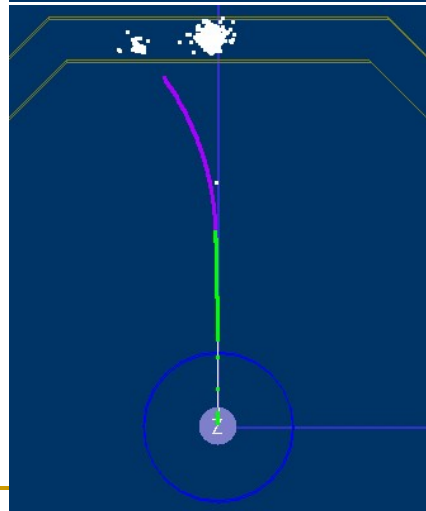

- FullLDCProcessor:
 - Two LDCTracks:
 - One in Silicon Trackers
 - One in TPC

- LEPTrackingProcessor:
 - Split into two TPCTracks
- FullLDCProcessor:
 - Refit while linking
 - Into two LDCTracks

The Correlation between Error of Pt and Chi2

- Study of χ^2 from simple Helix Fit,
 - see the $\Delta(P_t)/P_t$ v.s. χ^2/Ndf

• Large error of P_t , associated with bad χ^2

• The earlier the photon radiate, the larger error of P_t associated with good χ^2 is

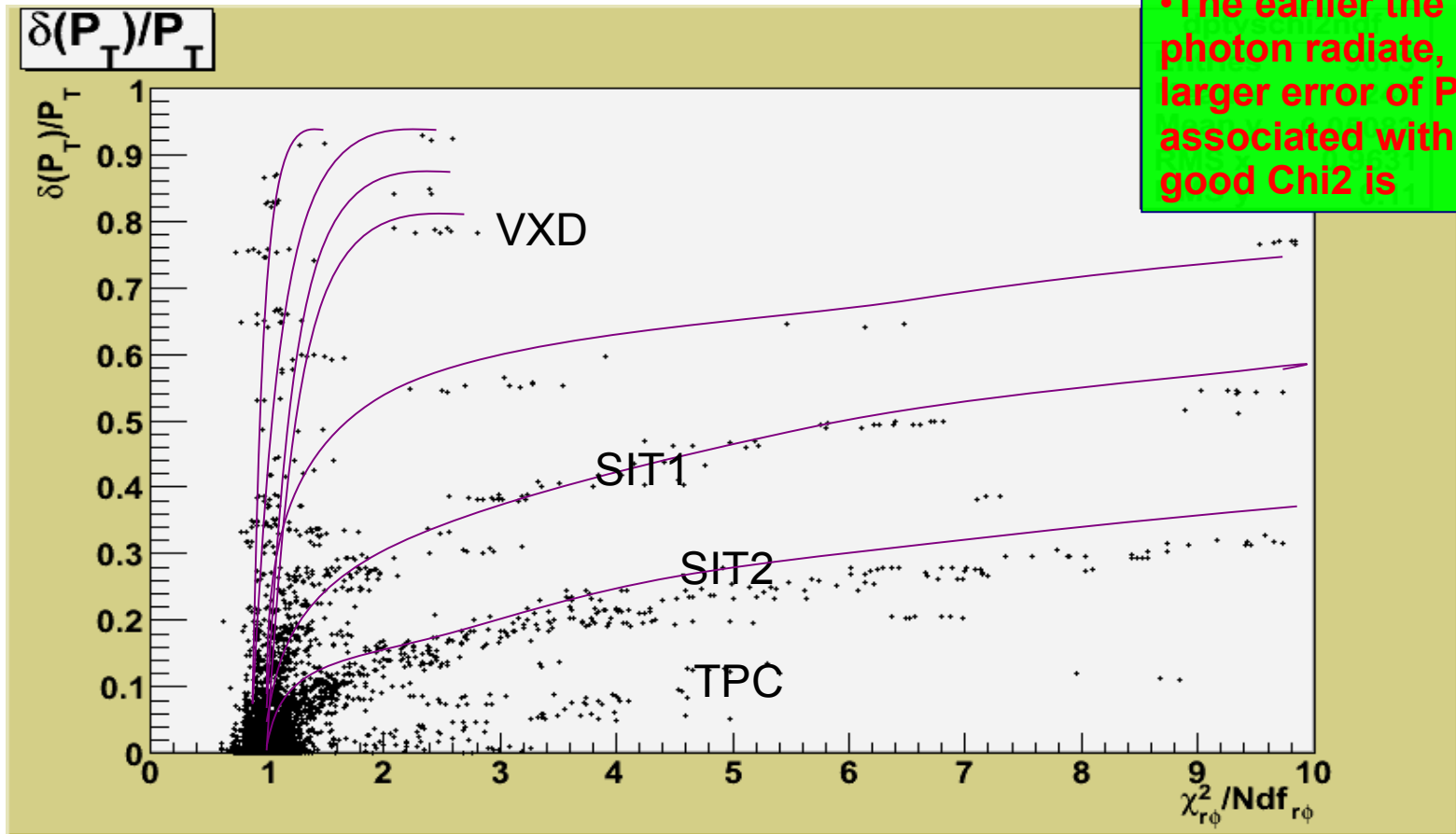

Material Budget in LDC01Sc

- 'Landscape' of passive material (Play with Monte Carlo Truth)
 - Where and How many photons radiated?
 - Energy loss of electrons \leftrightarrow Photon Energy?

10000 Events,
single electron,
50° to Z axis

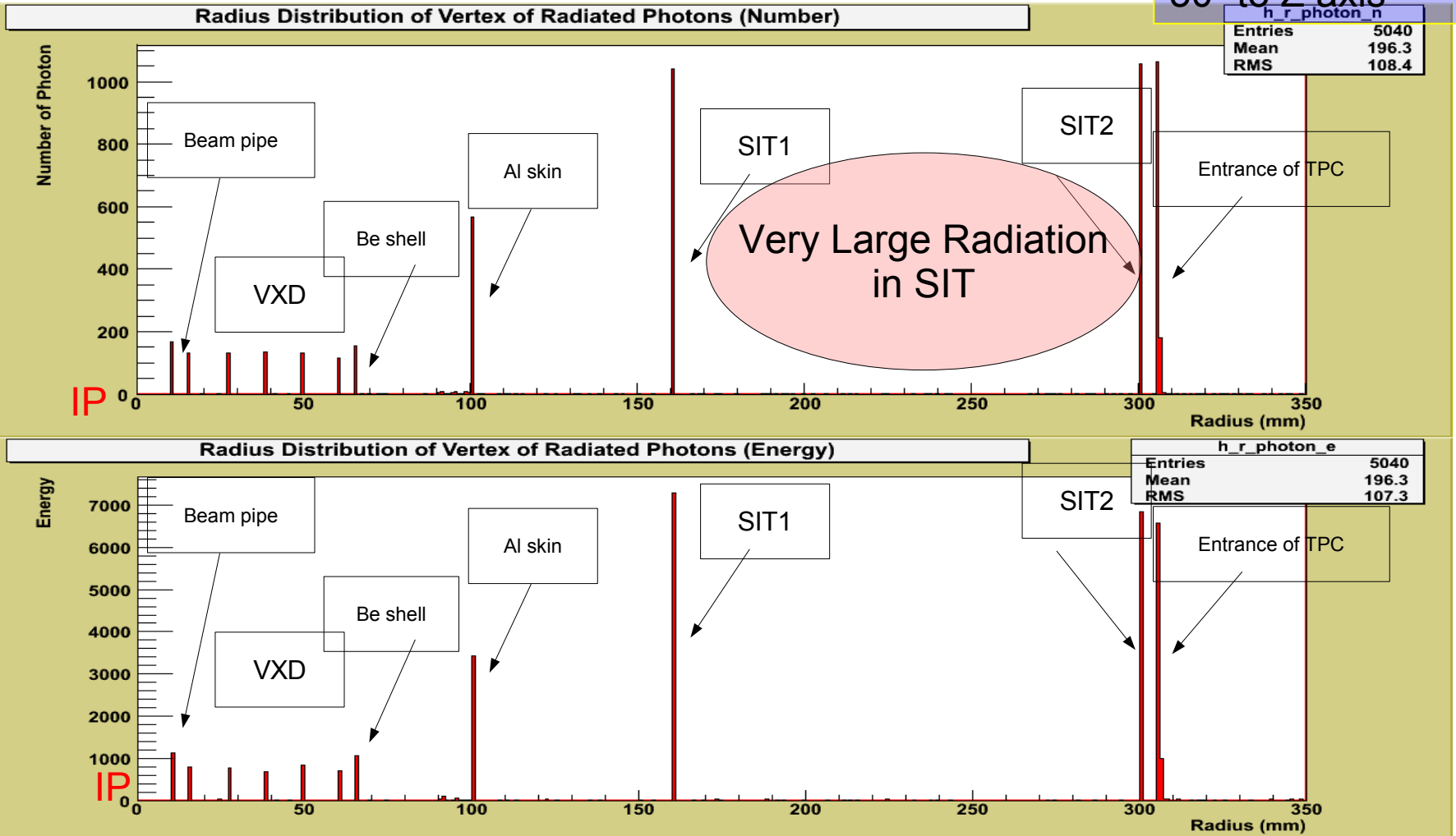

Long time existing Strange Material

- **Strange Material: "silicon_8.72gccm"**
 - Atomic number ($A=26.98$) , same as Silicon
 - Charge number ($Z=13$) , same as Silicon
 - Density 8.72 g/cm^3 (pure Silicon is 2.33 g/cm^3)
 - Radiation Length ($X_0 = 93.7 * 2.33 / 8.72 = 25 \text{ mm}$), where 93.7 mm is the radiation length of pure silicon
- **Exist since Brahms (used for TESLA TDR !?)**
 - TESLA Simulation and Reconstruction software
 - To account for the additional effects which are caused accompanying materials come together with the silicon sensors.
- **Still Existing in Mokka SIT00 and FTD00 Drivers**

Long time existing Strange Material

- Proper Solution for Accompanying Material:
 - Introduce a support layer together with each sensitive silicon layer
 - New Mokka SIT Driver (SIT01) Implemented
 - 'real' silicon instead of the strange one



SIT00

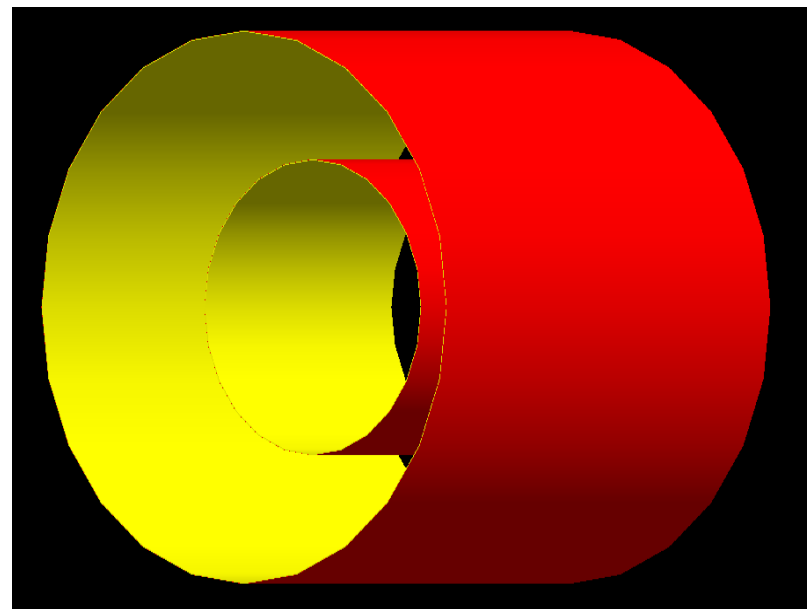

SIT01

Geometry of SIT01

■ Basic Geometry:

layer_id	inner_radius (mm)	half_z (mm)
1	160	380
2	300	660

■ Materials and Thickness

- Thanks to Aurore Savoy Navarro and SiLC Team to provide the information of thickness of silicon and total thickness in X0

	material	X0 (mm)	Thickness (mm)	Thickness in X0
sensitive part	silicon	93.7	0.2	0.21 %
support part	beryllium	352.8	1.01	0.29 %
Total				0.5 %

Comparisons of SIT00 and SIT01

■ Material Budget

- SIT00: $1.2\%X_0$ each layer

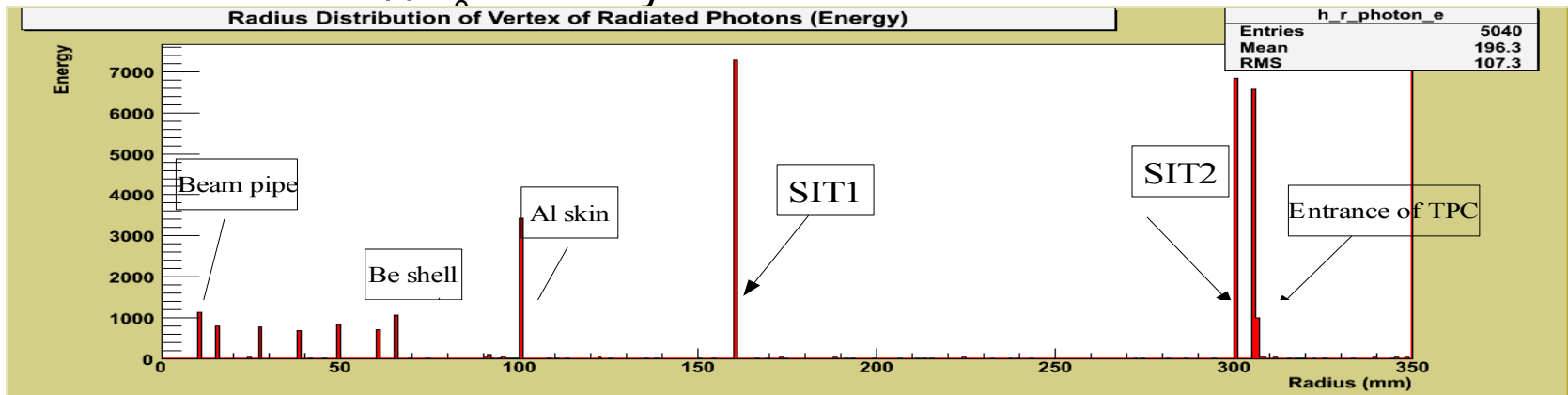

- SIT01: $0.5\%X_0$ each layer

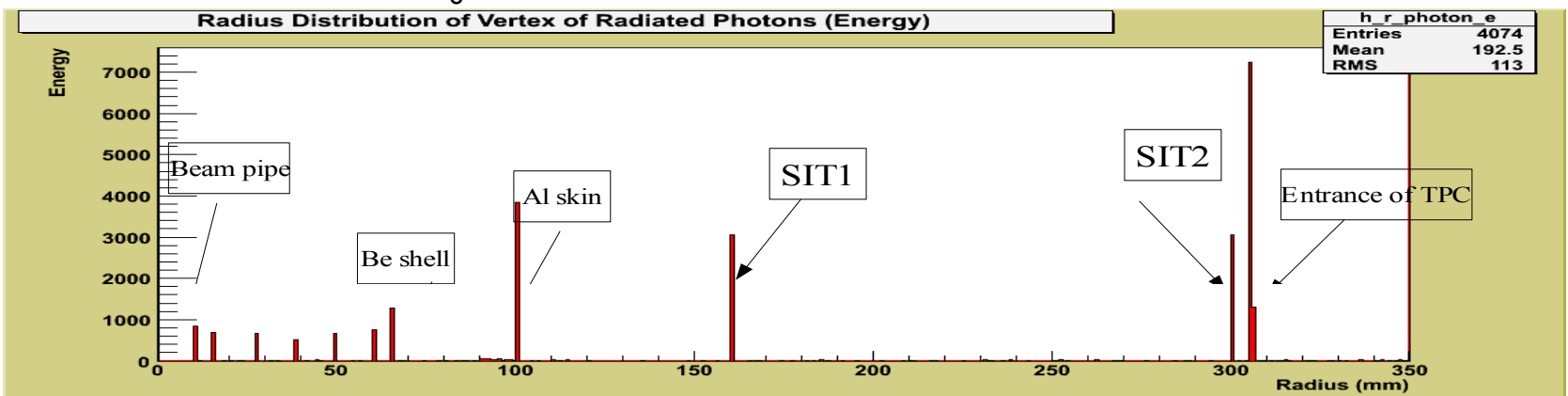

Comparisons of SIT00 and SIT01

10000 Events,
single electron,
50° to Z axis,
One track
events
considered

- Reconstructed Transverse Momentum
 - SIT00:
 - Sigma: 7.532×10^{-5}
 - Events # in peak: ~500
 - SIT01:
 - Sigma: 6.716×10^{-5}
 - Events # in peak: ~600
 - Sigma Decrease 10.8%
 - Events # in Peak Increase 20 %

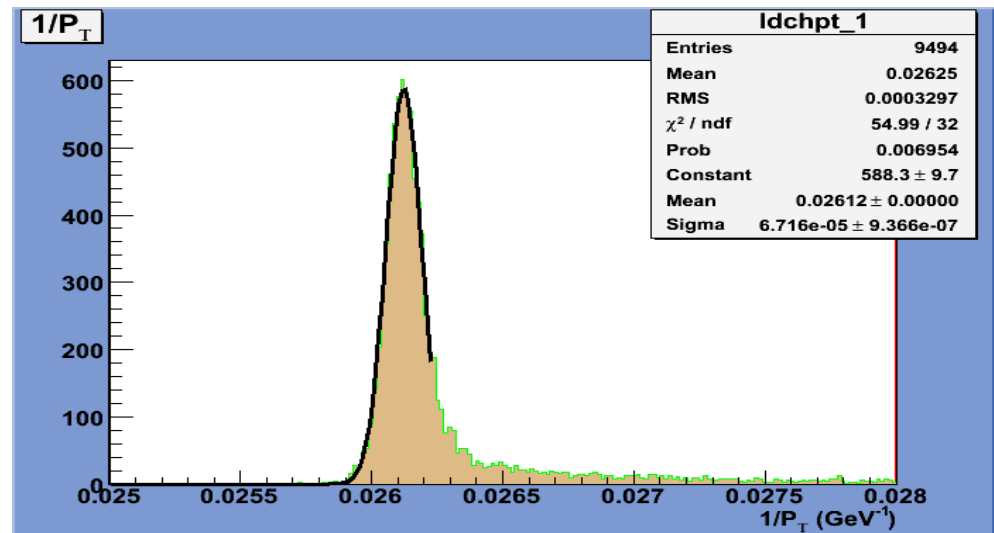
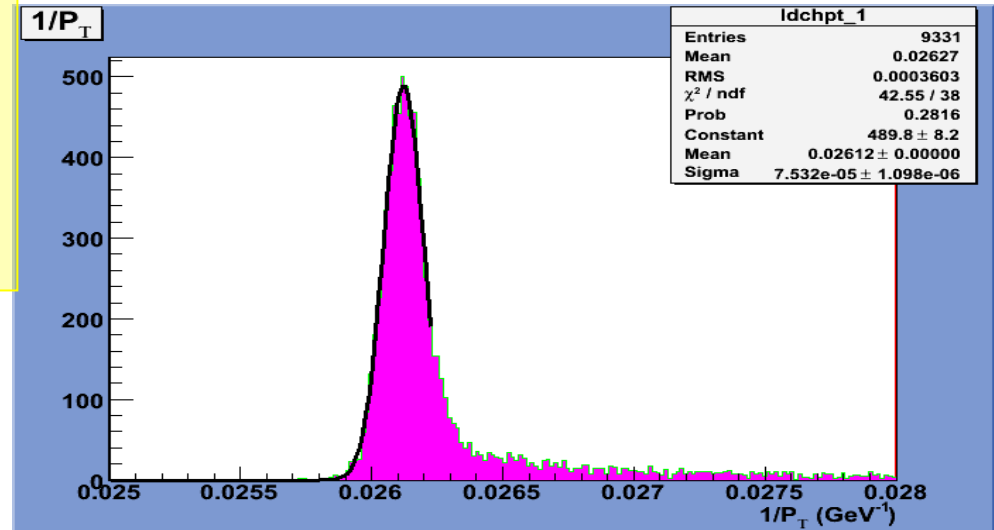

Conclusion and Next Steps...

- SIT01 driver will be included in next Mokka version, same job will be done for FTD
- Optimize the electron measurement
 - High efficiency and purity electron finder

Backup Slides

Techniques of LDC Track Reconstruction

