

TPC R&D Activities ongoing at



UPDATE

Matthias Enno Janssen¹

Markus Ball¹, Ties Behnke¹, Ralf Diener², Andreas Imhof¹,
Katsumasa Ikematsu¹, Matthias Enno Janssen¹, Alexander Kaukher³,
Krzysztof Komar¹, Joachim Mnich¹, Oliver Schäfer³ and Adrian Vogel¹

¹DESY, ²Universität Hamburg, ³Universität Rostock

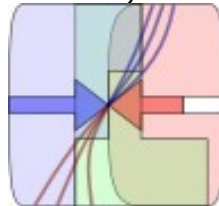

Universität
Hamburg



Activities

- DESY TPC group is
 - participating in the Large Detector Concept for the ILC
 - studying TPC-prototypes with GEM based amplification device
- Hardware
 - Design and stability test of a field cage
 - Implementation of slow control system
 - Setup of an UV Laser system
 - for 2 track separation study
 - calibration tool for drift velocity
 - Test of TDC readout electronic
 - Designing & building a large prototype

Activities

- Analysis:
 - Studies of single point and
 - Two track separation capability in high magnetic fields
 - deeper understanding of fit systematics, comparison of different fitting algorithms and techniques
- Simulation
 - Studies of neutron BG in the TPC using full MC simulator (Mokka)
 - MC studies for TPC prototype
 - pad geometries studies
 - Understanding of GEM signal generation

Studies with Laser beams

- Goals
 - Testing of track separation capability
 - Measurements of gas properties: **drift velocity**, diffusion
- UV-Laser
 - Wave length: $\lambda = 266\text{nm}$ (NdYAG)
 - Pulse length: $< 6\text{ns}$
- Advantage
 - Controllable and reproducible tracks
- Disadvantages
 - Different ionization mechanism: laser v. MIP (cosmic muon)
- Prototype TPC
 - Length 1050 mm, \varnothing 380 mm
 - **Quartz windows: 55, 305, 955 mm**

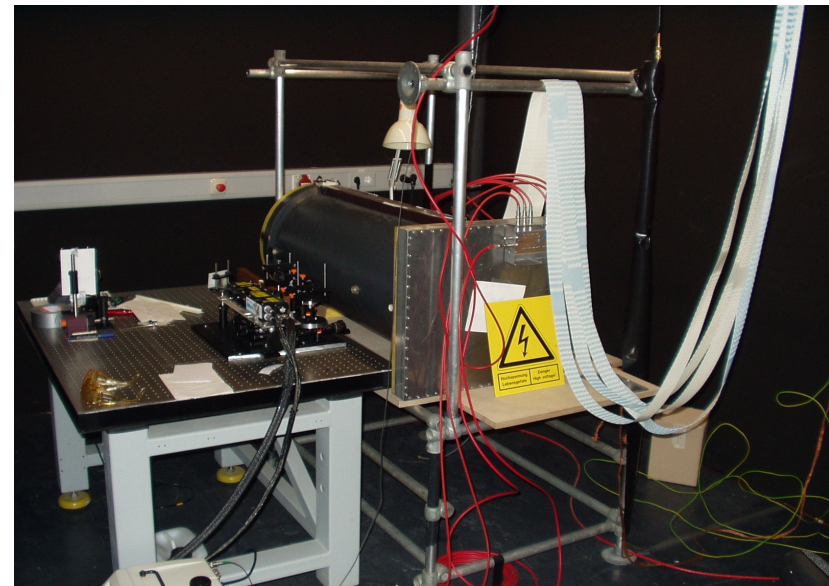

Slow Control System

- Slow control parameter for TPC
 1. Gas parameter
(p, gas flow, O₂, H₂O)
 2. Environment condition
(p, T, humidity)
 3. Electrical conditions
(HV drift field & GEMs)
 4. (Magnetic field)

- 1.&2. installed in a rack
 - Use industrial standard for read out

- 3.&4. controlled separately

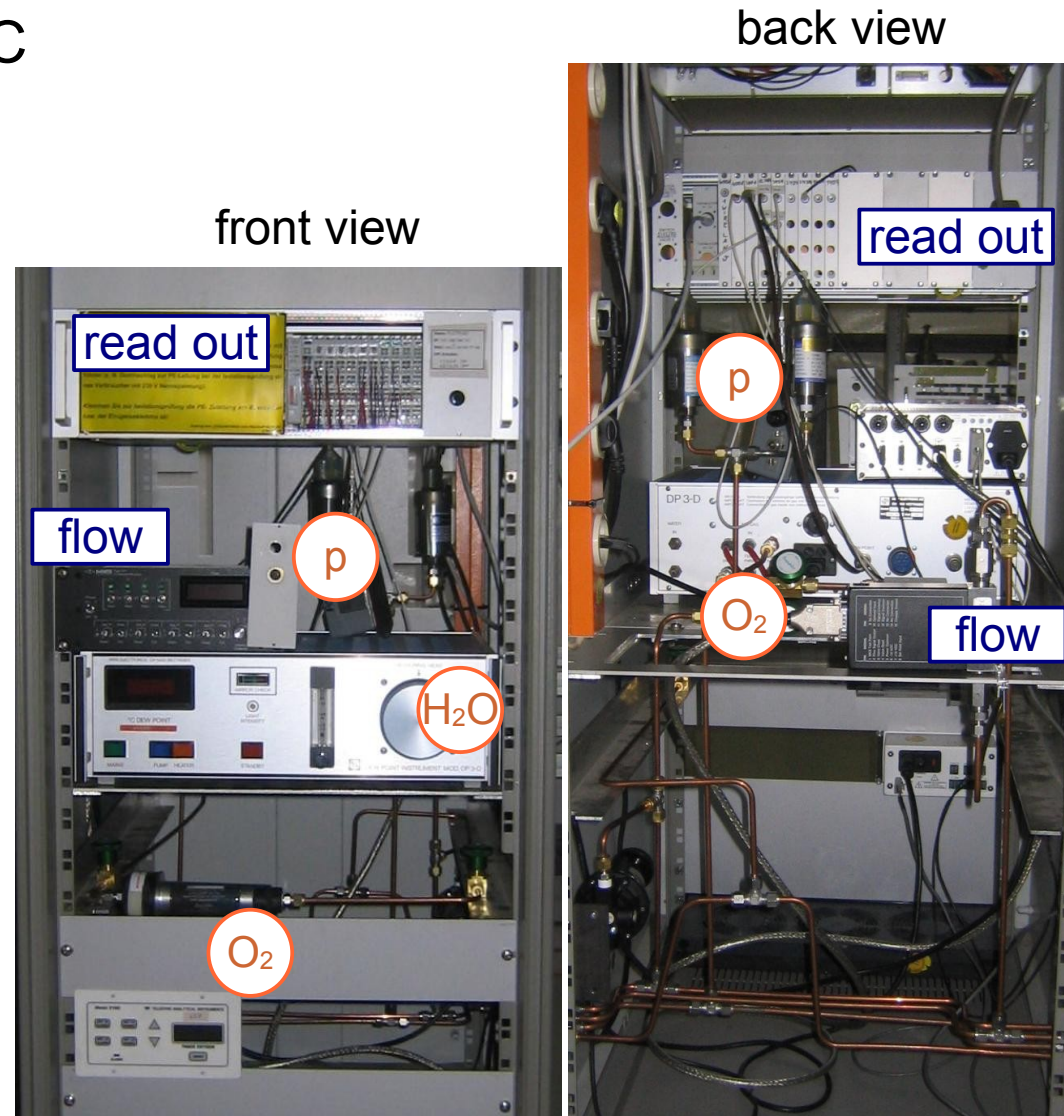

Measurement of Drift Velocity

- Setup for drift velocity scan between 120 – 200 V/cm
 - 2 laser beams shoot at the same time but at different well known positions through the TPC
 - Count the reconstructed time for every hit
 - Gaussian fit to the time distribution and calculate drift velocity

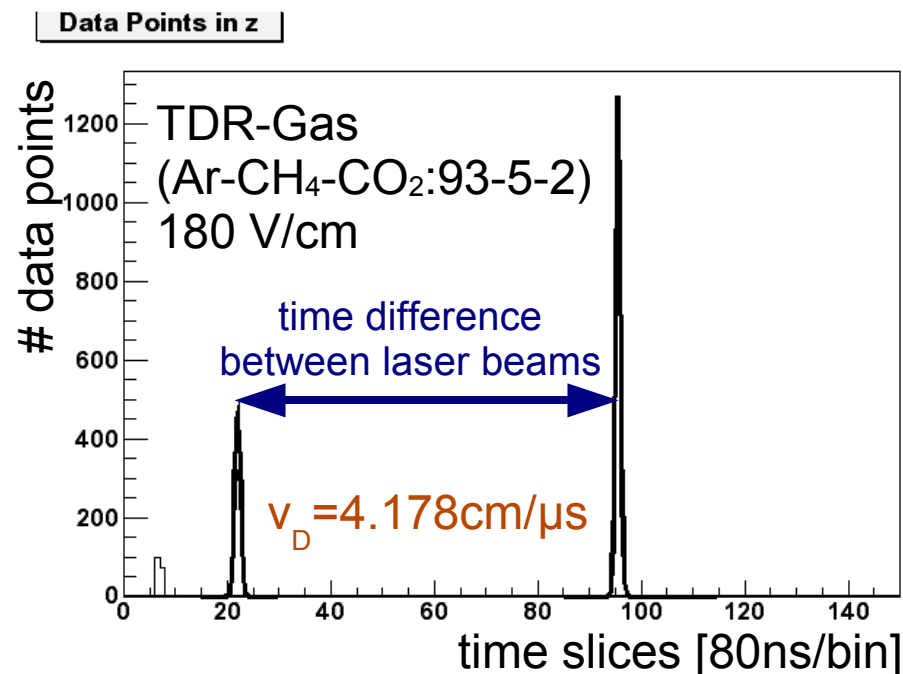
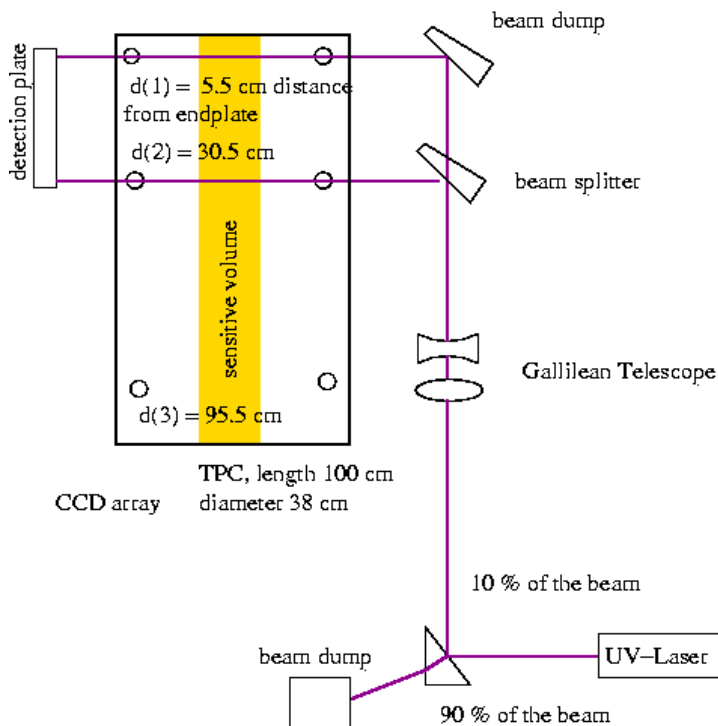

Drift Velocity & Water Content

- Compare two complementary methods for measuring the water content
 - Direct measurement: slow control
 - Indirect measurement: compare drift velocity scan with Magboltz prediction for different water content

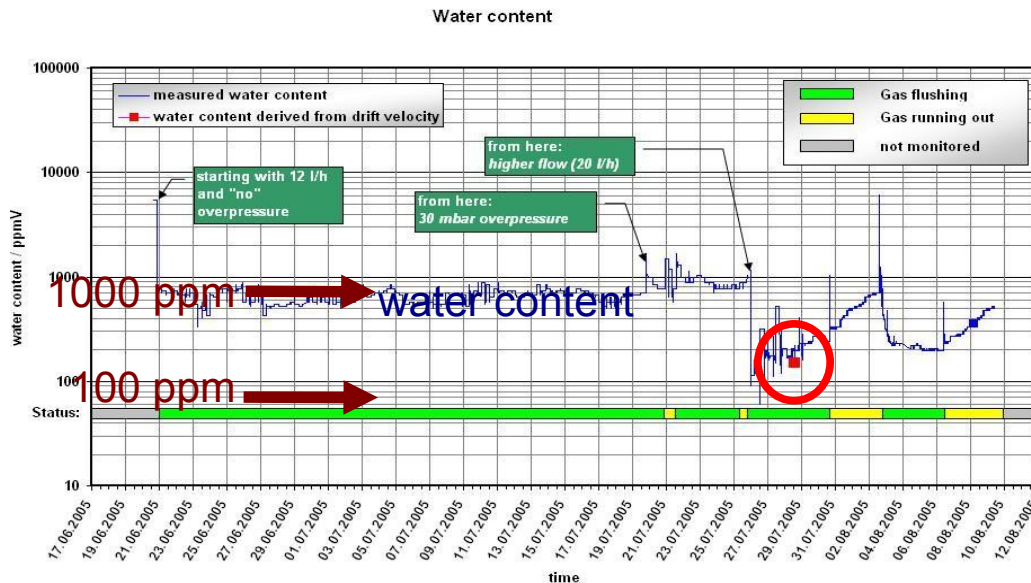

- First measurement seems to agree at 150 ppm water content, but ...

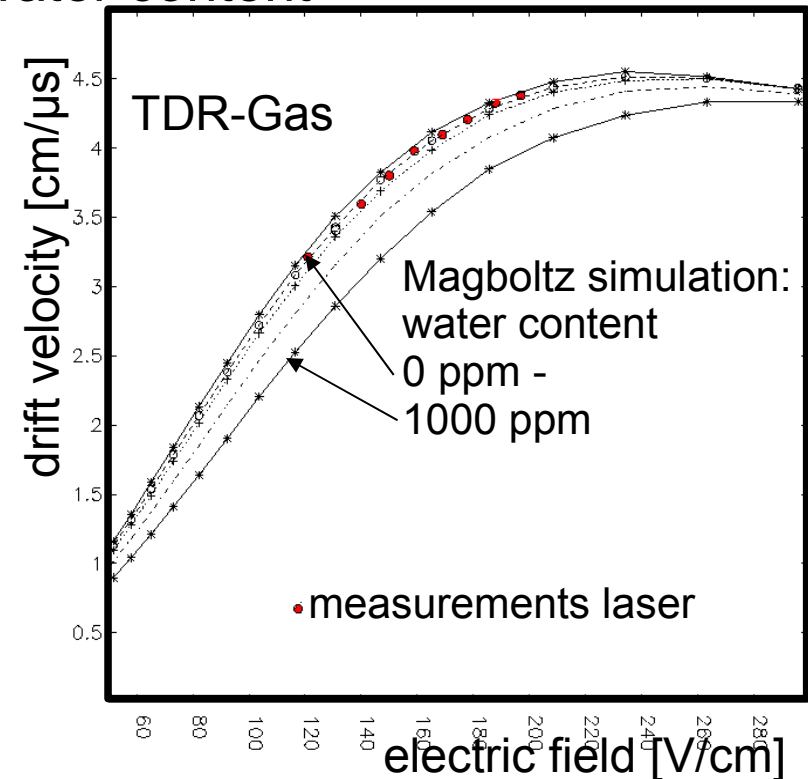

Drift Velocity & Water Content

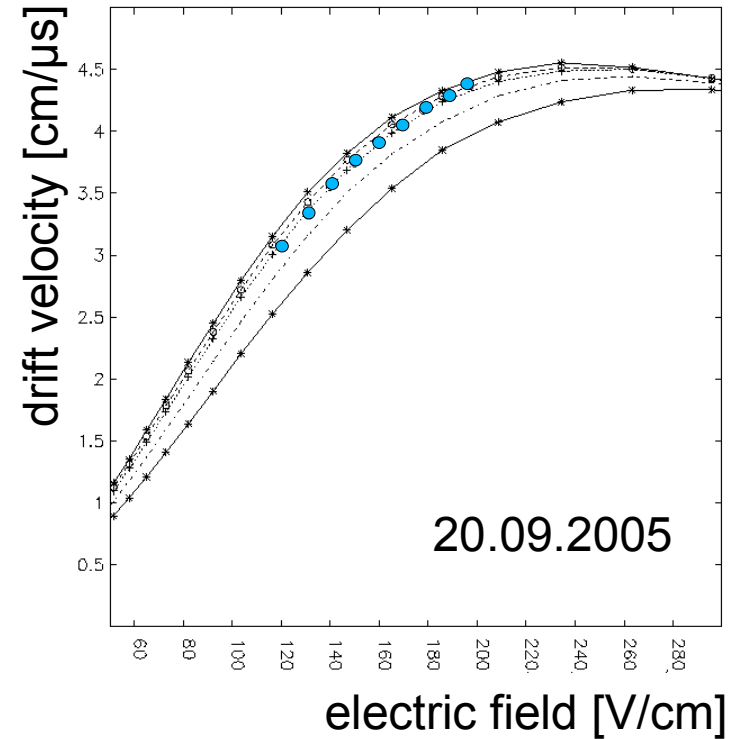
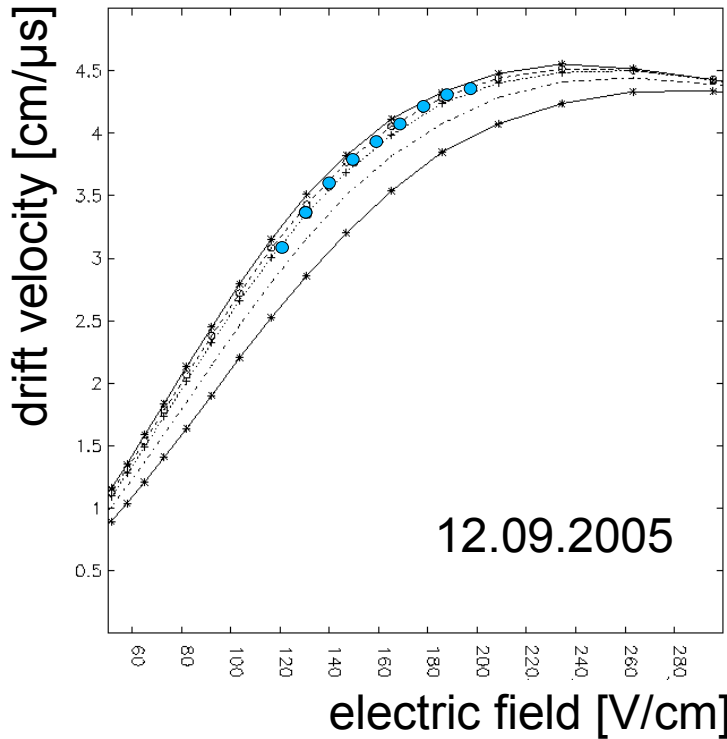

- Direct measurement with the slow control at the **outlet** of the chamber: **580 ppm** **1120 ppm**
- Discover leak at the end plate:
 - Assumption:
water measured by slow control is not in the drift volume

Drift Velocity & Water Content

- Direct measurement at the **inlet** of the chamber
 - Better agreement
 - Gas seems to be polluted after passing the drift volume

- Test for consistency
 - Introduction of water 'by hand' at the inlet (before direct measurement)

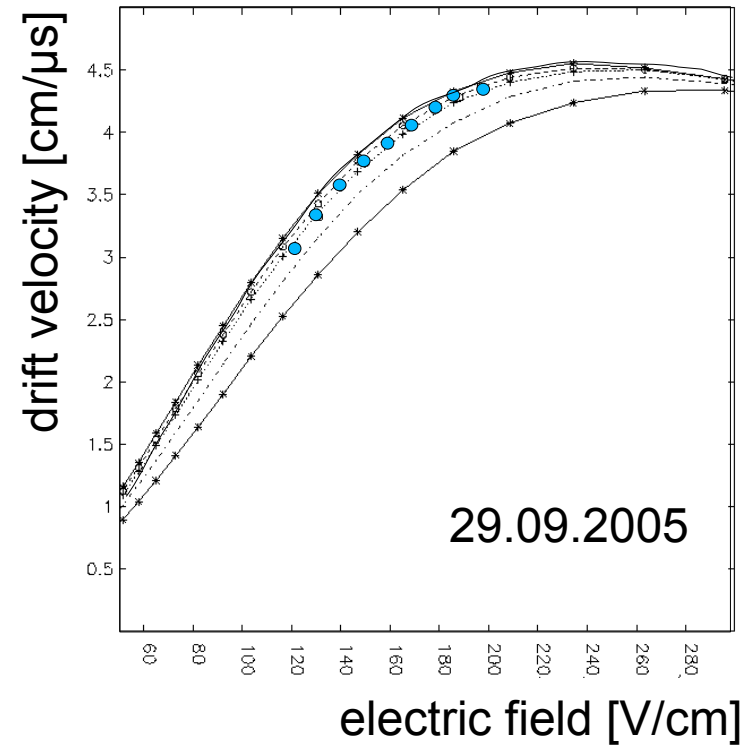

slow control: 91 ppm

Drift Velocity & Pressure

- Replace electric field E with reduced field E/p to take pressure into account
- Drift velocity measured at electric fields at the slope are most sensitive to pressure variation

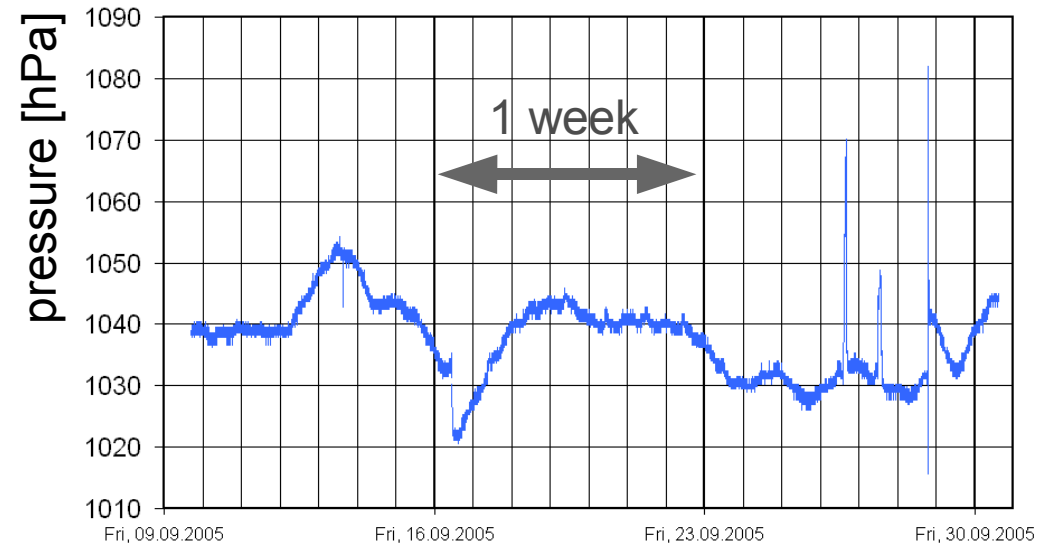
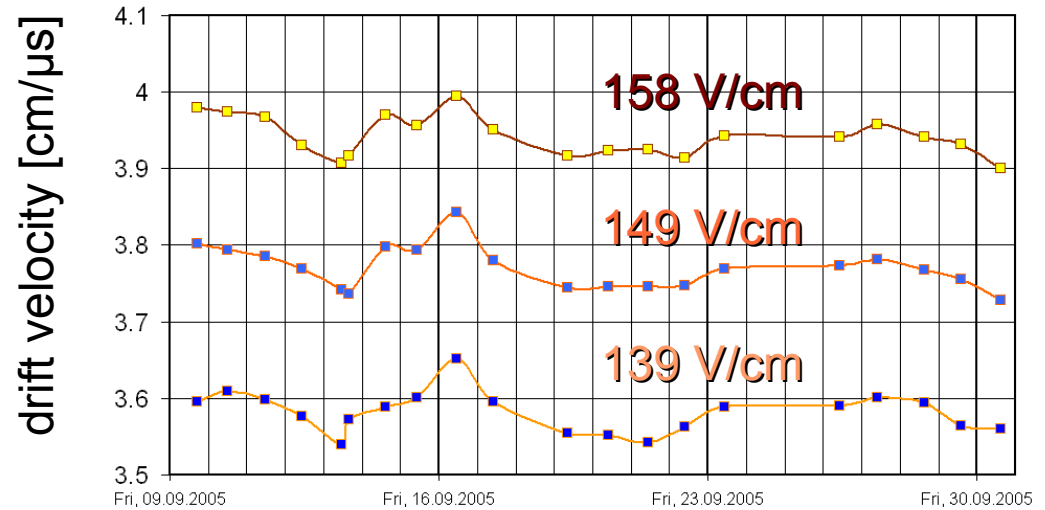
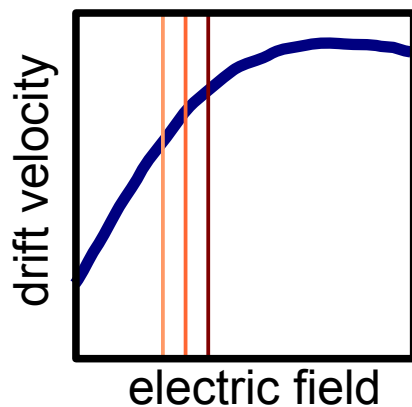

Drift Velocity & Pressure

- Anti correlation expected
- Correlation coefficient for 139 V/cm is -0.66

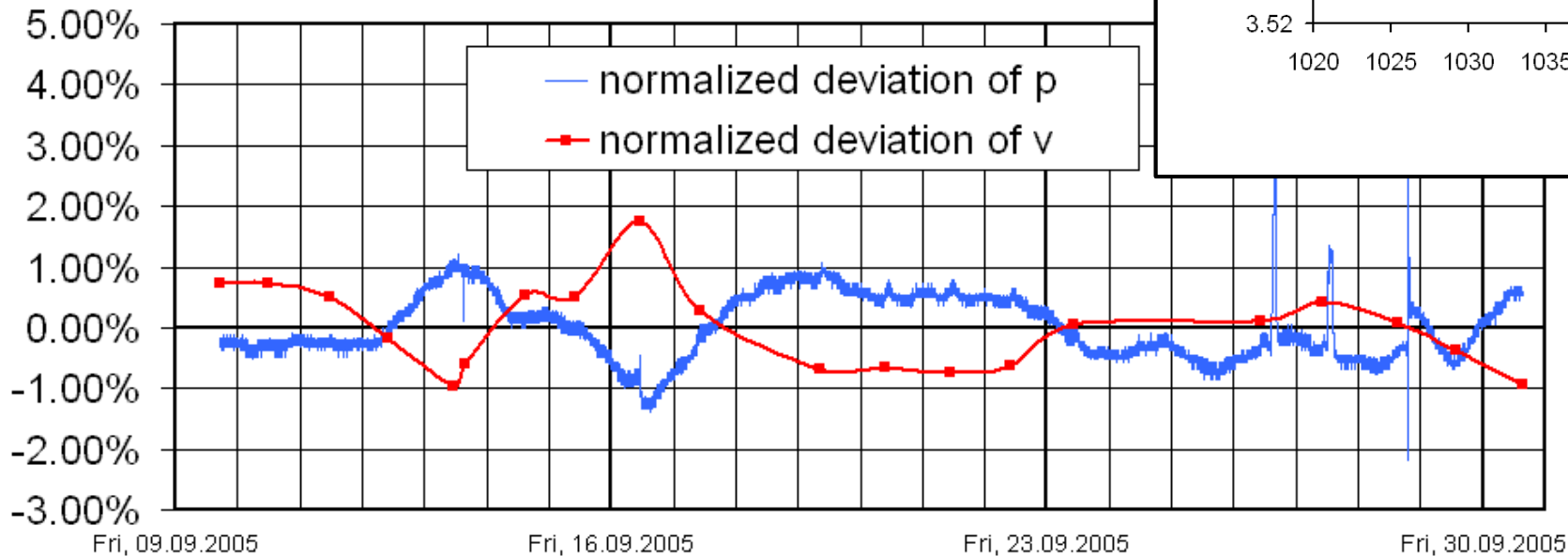
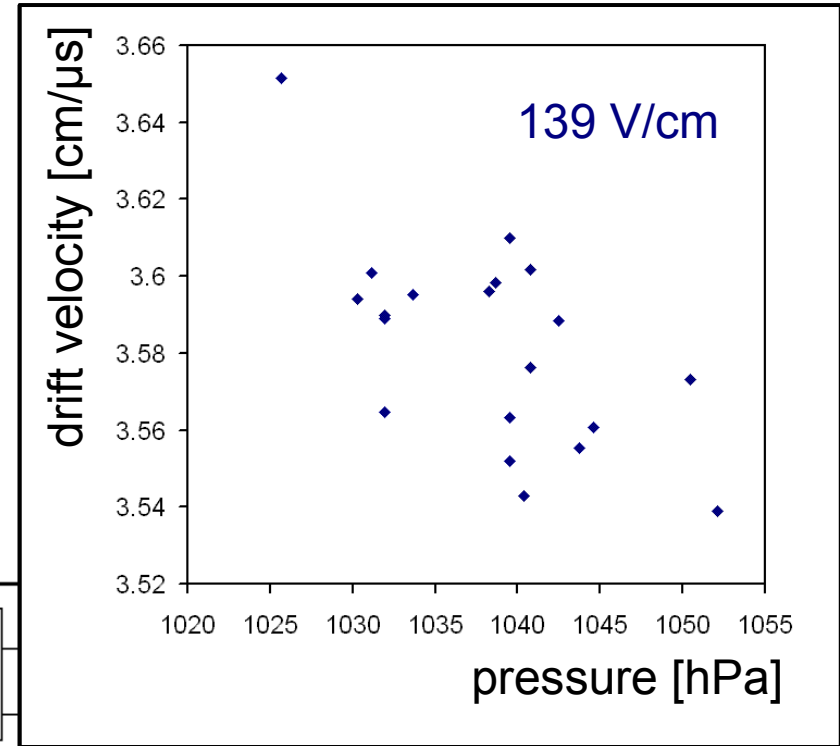

TDC based Read Out

- Principle of measurement

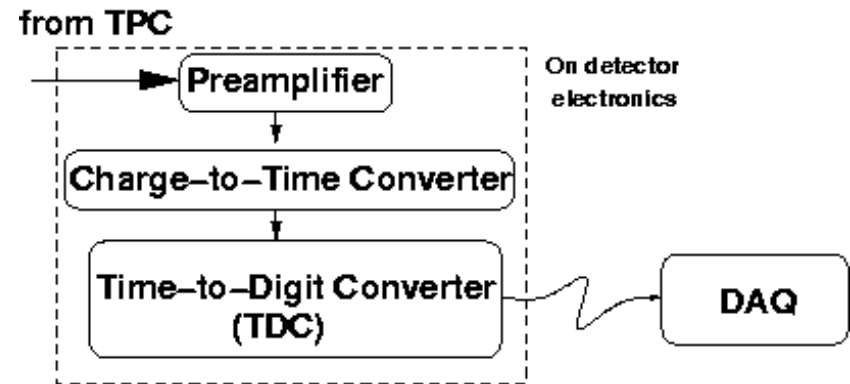
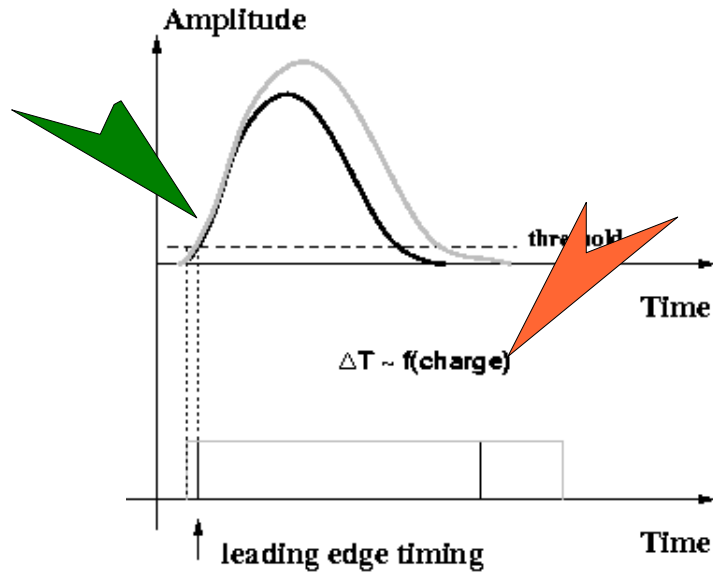

- leading edge timing
 - Method to obtain z coordinate
 - Depends on signal height: 'Time Walk'
- charge to time conversion
 - Coordinate in $r\phi$ plane
 - Measurement dE/dx

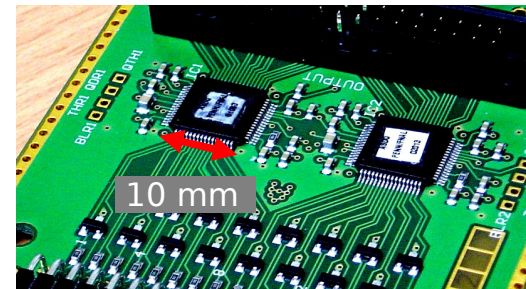

TDC based Read Out

- Data taken with laser setup
 - use of one beam at 305 mm
- Some effects on precision of the drift time measurement:
 1. Trigger jitter (~1...2 ns)
 2. GEM timing (5...12 ns)
 3. 'Time walk' due to signal variations in amplitude
 4. Time measurement error (~1 ns)
- At 305 mm drift length:
RMS 8.5 ns ► 0.4 mm

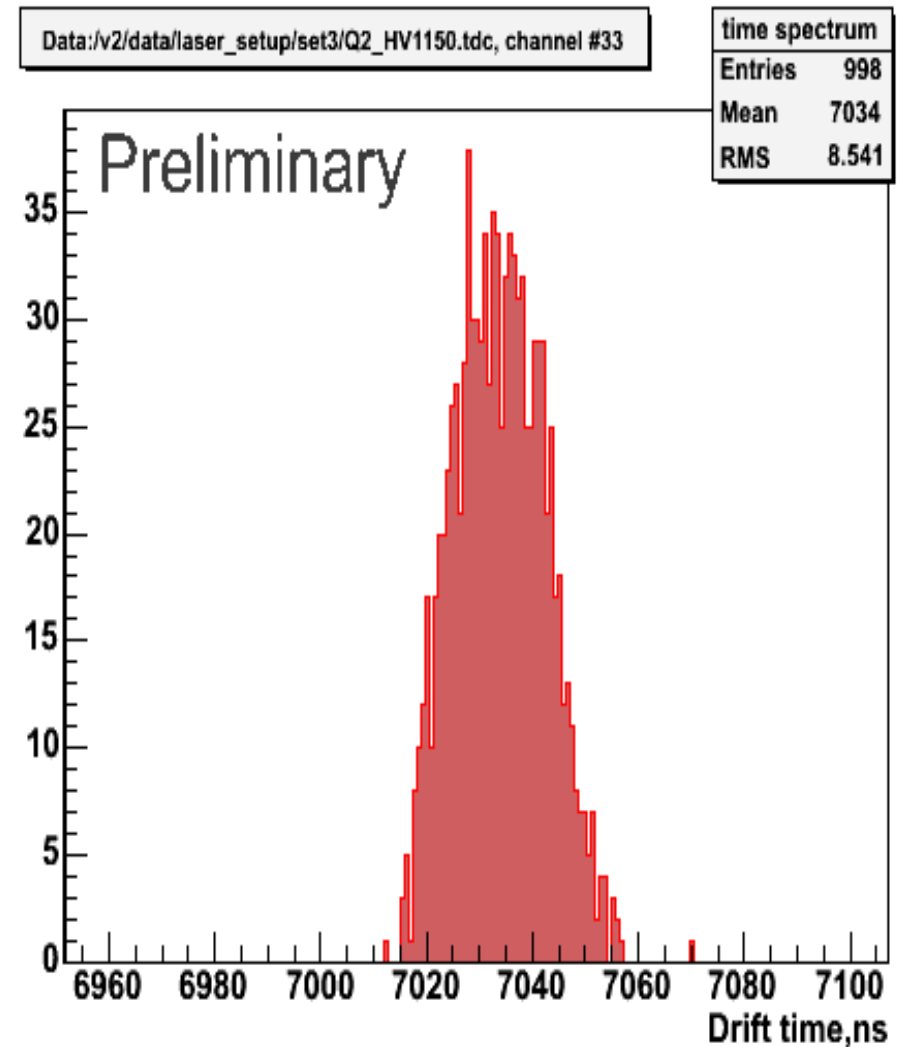

Simulation of GEM-Signal

- Goal: space-time evolution of the GEM signal for a segmented pad plane
 - Point resolution and
 - Double hit separability in drift direction
 - Readout electronic (rise-time, shaping time, etc.)
 - Signal of neighbour pads (resolution in r - ϕ)
- Obtain a realistic wave form of the GEM signal as a function of
 - Pad geometry
 - GEM structure
 - Gas and
 - Electronic properties

Concept of Toy Simulation

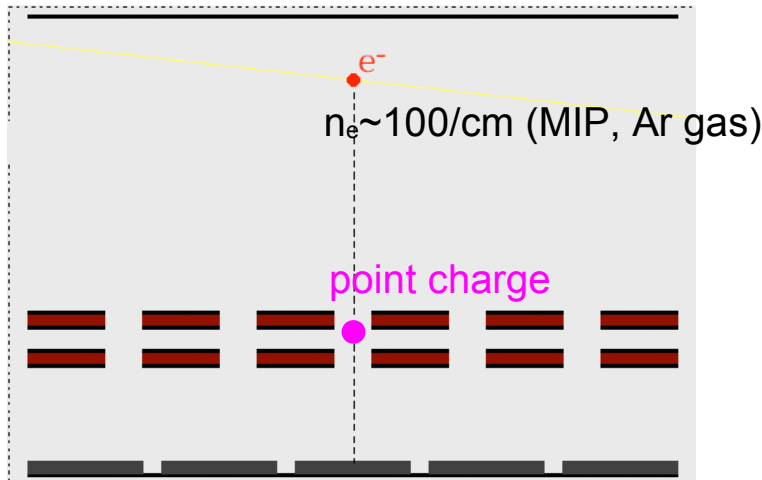

- Assumptions
 - Ignore ion velocity (1000 time slower than electrons)
 - Ignore size of electron cloud (for 1 primary electron) because it is small enough
 - Electron cloud moves to the anode plane along centre axis of GEM hole

- For simplicity: divide in two steps

1. Amplification stage

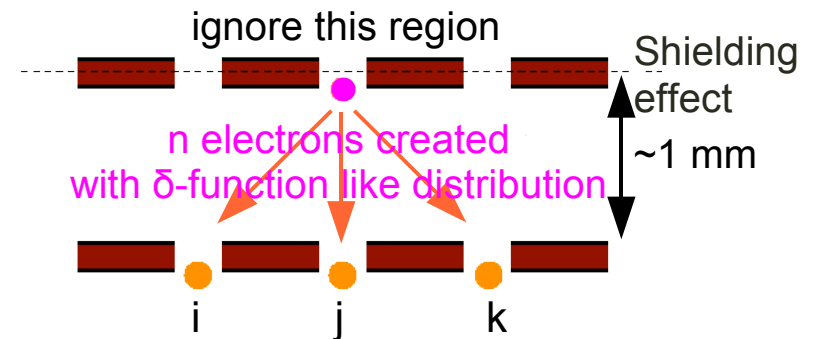

2. Induction state

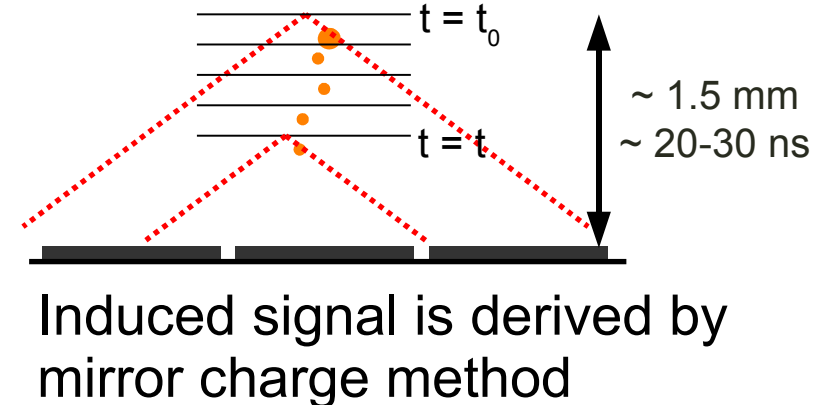

Summary & Outlook

- Laser is working as a multi-purpose tool
 - Measurement of gas properties: e.g. drift velocity
 - Consistency check for slow control
 - Water content measurement: needs further testing
 - Pressure: showed expected correlation
 - Test of track separation capability: ongoing
 - Resolution studies: use of reproducible track generation
- Electronic development:
 - TDC based read out is working
 - First results for resolution are promising
- Simulation to answer time dependence of the GEM signal is on the way